

DeLaval calf feeder CF150

Efficiently feeding your future



DeLaval calf feeder CF150 is a durable, low maintenance solution designed to feed your calves individually.

Prioritising calves protects your farm's future

Profitable milk production requires strong, healthy cows. To help ensure your dairy farm's future success, you need to correctly feed its greatest asset from the very beginning. After all, healthy calves grow up to become fertile heifers that calve easily and produce large quantities of quality milk.

Effective calf feeding and related management can minimise future herd health problems, lower costs, maximize income and create a stable basis for the growth of your business. The optimal approach is to feed your calves often with small individually adapted portions. This method allows the calves to properly digest their feed, promotes good growth and limits feed wastage. DeLaval calf feeder CF150 prioritizes effective calf feeding. This robust and economic solution is designed to reliably and correctly feed each calf individually.

High capacity - good return on investment

DeLaval calf feeder CF150 is the high capacity, economical answer to an efficient feeding programme. This durable system offers you a high return on your investment by simultaneously handling the feeding of up to 100 calves, utilizing four CF150 calf feeders, controlled by one processor.

Investing in a computerized feeding station pays for itself quickly. The processor can include pre-setting of each calf's feed ration to include the exact amount of concentrates as required. This will allow you more time focus on other areas of your business. Easily installed on or near the station, the processor offers a faster track to efficient calf management and its user-friendly software simplifies your daily feeding routine.

DeLaval calf feeder CF150

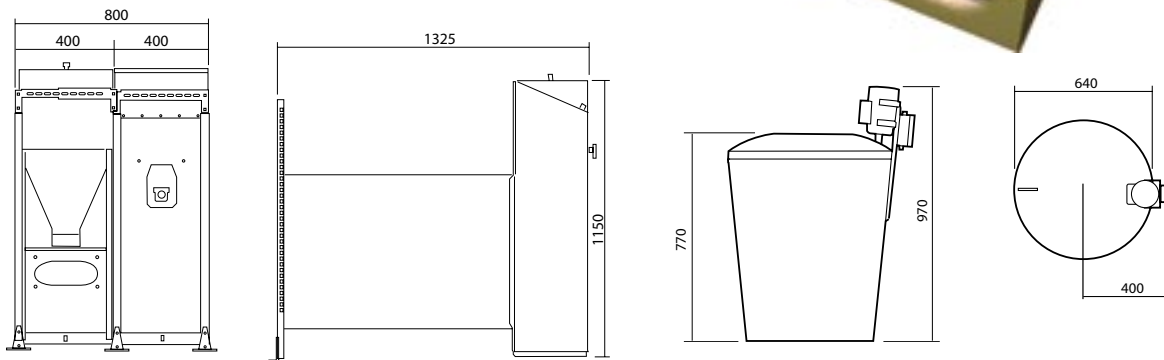

CF150

| | |
|------------------------------|----------|
| Powder milk | x |
| Fresh milk | x |
| Sour milk | x |
| Built-in milk heater | x |
| Individual additives | - |
| Extra milk feeding station | optional |
| Concentrate feeding station | optional |
| Feeding processor | x |
| Stainless steel construction | x |
| PC interface | x |
| PC connection | optional |

Accessories

- Concentrate feeding station, max 4 units total
- Extra milk feeding station, max 4 units total
- Swing-over gate for grouping the calves
- Extra milk tank with mixer

Primary functions

- Powerful user-friendly processor
- Menu driven program, easy to understand
- Exact, individual milk and feed rations
- Feeding plan for milk and concentrate
- Automatic weaning function
- Adjustable temperature of the milk
- Intensive mixer, which can mix powder milk
- Quick learning device for calves

Data

| | |
|------------------|--|
| Milk tank volume | 150 litres |
| Electrical data | 230V AC, 1 ph, 50-60 Hz, 16A |
| Number of teats | 1/milk feeding station |
| Capacity | With 1 milk feeding station Up to 25 calves |
| Milk heater | 1250 W |
| Mixer | 200 W |